



Z-SP SERIES
Owner's Manual

Before operating the unit, please read this manual thoroughly and retain it for future reference.

MISSION STATEMENT

Committed to Excellence

ZAPCO is dedicated to the pursuit of audio fidelity. Our prime objectives are to design and manufacture audio products of unsurpassed quality, to provide unparalleled support and service for these products and to conduct business in a manner that will enhance the quality of life for all involved.

Experience (Knowledge from doing)

There is absolutely no substitute for experience; that is a simple fact of life. Another simple fact is that ZAPCO has, for over forty years, been the leader in defining quality standards for the car audio industry.

These years of experience have led to a thorough understanding of the challenges that are unique to the world of car audio. ZAPCO's relentless quest for sonic purity consistently yields imaginative designs that utilize the most innovative technologies. The resulting products set the criteria by which all others in the industry are judged.

Table of Contents

A new standard in Sound Quality	2
Before you start your installation	5
Planning your power connections	6
Wire size	7
Mounting your Z-Series SP amplifier	8
Inputs and Controls	9
Z-150.2 SP / Z-400.2 SP Input Ends	9
Z-150.4 SP Input Ends	10
Z-150.6 SP Input Ends	11
Speaker Wiring of the SP Amplifiers	12
Z-150.2 SP / Z-400.2 SP Speaker Wiring	12
Z-150.4 SP Speaker Wiring	14
Z-150.6 SP Speaker Wiring	17
Technical Specifications	20

Special Note on Z-150.6 SP Amplifier

Please use caution when connecting speakers to channel 5. Because of the layout of the Z-150.6 SP the positive and negative terminals of channel 5 are reversed from the rest. We find that some units left the factory with the terminal colors wrong on CH5. The printing on the amp is correct but still it can be confusing when the colors are different. We have corrected this but please check you Z-150.6 SP and note the correct positions as below.



A new standard in Sound Quality

Congratulations, on the purchase of your new Zapco Z-Series SP amplifier. We believe you now have the finest sound available in a car sound amplifier, and we think you should know a little bit about what makes this amp unique in a world of so many so-so products.

The birth of the Zapco SP amplifiers

In 2012 Zapco introduced the new Z-Series of SQ amps. These amps were not conceived so much by our engineers, as by input from audiophiles and car sound fanatics around the world. Starting about 2004, at Zapco training seminars in Asia and in the EU, we began running into audiophiles who were changing certain internal components in our amplifiers to achieve what they felt was better quality sound.

With that in our minds, we developed the Z-Series amps with less measuring and more listening. So for the Z-Series of Zapco amplifiers, we experimented with internal components and new circuits to see if we could take our amps to the next level of sound quality by investing in different internal components and circuit designs.

The resulting Z-series and eventually the Z-series LX amps were the results of this unique development method. These amps have been virtually unbeatable on the Car Sound Competition circuit.

But amplifiers designed solely for sound quality run warm, and on "the street", cruising the boulevard, or at the park with the doors open and the system cranked full on, these amps could be driven into protection.

How do we get Z-Series sound in an amplifier for full-on, full-time cranking? We couldn't! It wouldn't work without a much bigger chassis or a sacrifice in sound quality. So we had to find a new way to build the amps.

And we did! The Z-150.2 SP and Z-400.2 SP stereo amps, Z-150.4 SP 4-Channel amp and the 6-Channel Z-150.6 SP are the Zapco SP, or Super Power, amplifiers.

To reach our goals we first developed a new forced air cooling system in a chassis with internal heat sink fins and fans to blow the heat off the chassis. Fans blow on to the fins to move air down the chassis, and the side vents down the side create turbulence that sends hot air out and cold air in along the whole length of the amp.

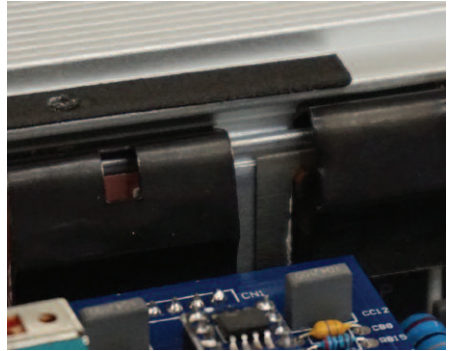
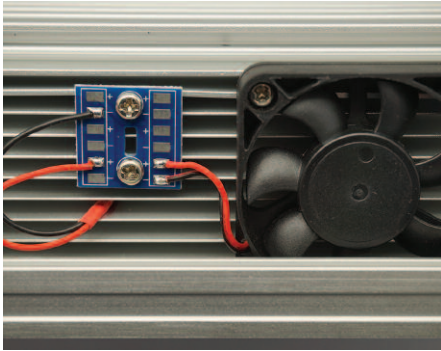

This got us half way there. Then we found a new space-age material, to insulate the output transistors, that can pull heat off devices much faster than the standard insulators. So now we could transfer the heat from the devices to the chassis faster then pull the heat off the chassis faster.

The result: We now had an amplifier that you can crank up to full volume and play that way all day long. And, with a few upgrades in circuitry that we made, you also get:

- High Pass, Low Pass, and Band Pass crossovers
- x10 Range Switch for accurate crossover frequency selection
- Variable Sub Sonic filter using the band pass
- Variable Bass Boost
- Variable Gain
- Auxiliary RCA Output
- Available Dash Remote

In most amplifiers all these preamp controls give you more versatility but they also rob you of signal quality. But in the Zapco Z-Series SP amps, even with crossovers and bass boost you get over 103dB signal to noise ratio, less than 0.1% THD, and greater than 60dB channel separation. And the SP amps get a 10% power gain from increased thermal efficiency that reduces the "de-rating" of the output devices.

A quick rundown of the SP amp's unique features:

- Cooling fans with thermal speed control
- Insulator with 70% less thermal resistance of MICA for faster heat transfer
- Proprietary RCA connectors with extra heavy plating soldered directly on the PCB (Zapco design) with 6 ground lugs on each, for an absolutely secure mount
- Balanced and differential inputs with one tenth the normal resistance
- New Op-amp with lower noise than even the current LX amps
- Bass Boost that is out of the circuit when set to 0
- Capacitors with lower internal resistance and lower inductance (only just now appearing in the LX amps)
- Fine adjustment for bias in each channel
- A custom plaque with model and serial number lets them know this amp is special
- And new stronger packaging so this unique amplifier can be shipped with confidence



Proprietary custom RCA connectors

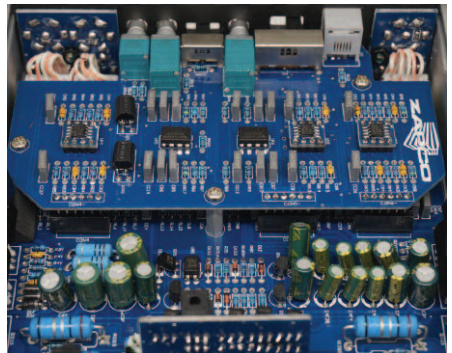

Lower ESR Caps and the new LME 49723 Op-amps

We sincerely hope you enjoy your new Z-Series SP amplifier as much as we enjoyed the time we spent developing it.

ZAPCO President
John Borges

A handwritten signature in black ink, appearing to read "John Borges".

Before you start your installation

ZAPCO highly recommends that a fuse or circuit breaker be placed within 18" of the battery. Although you will add a fuse or fuse block near the amplifier it is still a possibility that a pinched power wire between the component fuse and the battery could result in a short, or even a fire. The protection device should be placed where it can be accessed easily and all wiring should be routed safely and correctly according to the following guidelines:

Do not run wiring close to hot or spinning objects.

Always use wire grommets when routing wire through the firewall or any other metal panels.

Make sure that the potential for pinched wiring is avoided by routing all wires away from moving hinges and seats. This also includes brake, gas and clutch pedals, hood and trunk hinges, etc.

Continuous exposure to excessive sound pressure levels may cause permanent hearing loss. ZAPCO strongly advises that you use common sense when setting volume levels. If you experience ringing in the ears, it could cause permanent hearing damage!

When connecting our amplifiers to pre-wired stock speakers, care must be taken that there are no common connections between left and right speaker wires, i.e. two or more speakers using the same ground connection (very common in pre-85 cars), as this will cause the amplifier to go into immediate protection or may cause damage to the amplifier. Output connections are not common chassis ground. Please follow the hookup instructions in this owner's manual. Any questions should be directed to your local ZAPCO dealer.

Planning your power connections

The power end plates of the Zapco SP amplifiers carry the power connections and the speaker connections and vary somewhat by the number of channels. For example, the power end of the Z-150.6 SP below has (of course) speaker connections for six channels. One model, the Z-150.2 SP has on-board fuses, while all other models will require and in-line fuse with a rating as in the specifications page at the end of this manual. That said, the main 12-volt power input, the 12-volt turn-on wire, and the main Ground connections are common to all models.

- The gold connection at the interior of the end plate is the main power input. This must be connected to the vehicle battery's positive (+) terminal, and a main system fuse should be placed close to the battery.
- The silver connection at the outside of the end plate is the main ground or negative connection. This must be securely attached to bare metal at the vehicle frame, or other heavy chassis component with a direct connection to the frame.

Note: Seat bolts and seat belt bolts are NOT good ground points

- The small terminal between the main power and ground is the +12 turn-on input and can be connected to the head unit turn-on output wire. If none is available it can be connected to an accessory (ACC) terminal. You should avoid using any ignition-on (IGN) wire, as they can be noisy.

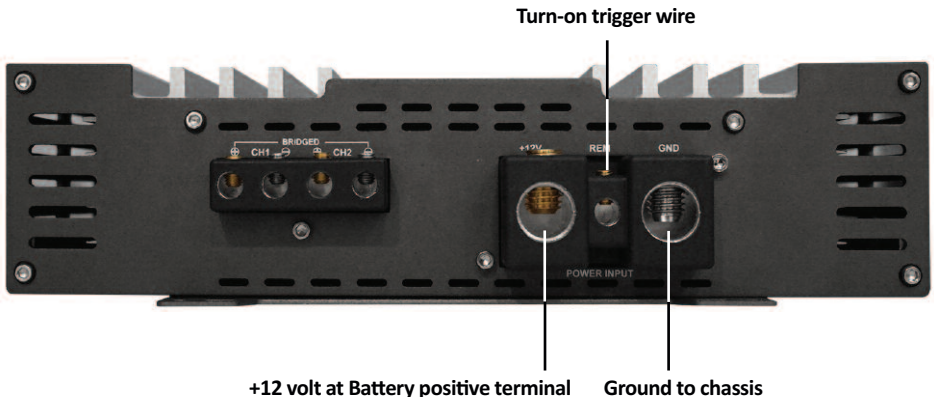

Note: The Z-Series SP amplifiers have terminals that do not require connectors. You simply insert a bare portion of wire and tighten the connection with the supplied Hex tool. As the wire conforms to the connector the connection can loosen. You should re-tighten the connection after about a week.

Some words about Power and Ground

Note: The second most common cause of underperforming amplifiers is insufficient power current or a poor power connection. The most common cause of underperforming amplifiers is insufficient ground current or a bad ground connection.

12-volt current: Battery Power works only if it travels in a complete circuit from the battery positive terminal to the battery negative terminal. Main power input, of course, is attached to the battery positive terminal. Ground current is returned to the battery through the chassis to the point where the battery is grounded.

The current available for your amplifier to use to produce power will be restricted by the smallest gauge of wire in the circuit and by the weakest physical connection in the circuit.

Wire Size

It's often surprising how many people will obsess about signal wire but routinely provide the amplifier with only a fraction of the current it needs to do its job. The most common wire gauge used in car audio is 10-gauge, and the most common location for amplifiers is in the trunk.

Wire Sizing Chart

	←----- Length of Run -----→							
	4 ft	7 ft	10 ft	13 ft	16 ft	19 ft	22 ft	28 ft
0-20 amps	14	12	12	10	10	8	8	8
20-35 amps	12	10	8	8	6	6	6	4
35-50 amps	10	8	8	6	6	4	4	4
50-60 amps	8	8	6	4	4	4	4	2
65-85 amps	6	6	4	4	2	2	2	0
85 -105amps	6	6	4	2	2	2	2	0
105-125 amps	4	4	4	2	2	0	0	0
125-150 amps	2	2	2	2	0	0	0	0

Let's look at a fairly small system. If you use a 50 watt/ch amp (25 amps) for the highs and a 100 watt/ch amp (40 amps) for the woofers, you need at least a 4-gauge and maybe a 2-Gauge wire to provide 65 amps at the trunk. Anything less and your car won't go boom. It'll just go Blap!

Note: It takes lots of current to make lots of power!

Remember! An electrical circuit is just that... a complete circuit. For current to travel, you must complete the circuit from the positive terminal to the negative terminal (which is connected to the vehicle frame). So what ever Gauge wire you use for power (B+) you must also use for ground (B-).

Note: A 4-gauge power wire needs 4-gauge ground wire!

Use the Wire Sizing Chart! Add up the fuse values on the amplifier(s) then choose the proper size wire based on the distance from the car battery to the amplifier location. Again, always use the same gauge wire for the main ground as you do for the main power. Always make your ground as short as possible and secure it to a clean solid surface, preferably the vehicle frame.

Mounting your Z-Series SP amplifier

Mounting your Zapco amplifier is easy. Just keep in mind a few guidelines:

- The amplifier can be mounted in any direction, on wood, metal, or carpet
- The metal chassis of the amp can be grounded or left isolated
- The amplifier requires adequate ventilation. Creating power creates heat, and cooling requires air. Position the amplifier with sufficient surrounding area for air supply and keep the end plate and side vents clear for internal cooling
- Keep the amplifier out of the engine compartment or other locations that may cause excessive heat or moisture
- Do not mount the amplifier to a subwoofer box or other place that may have excessive vibration

Setting Gains: Gain pots are not volume controls. Before you first turn on your system, you should make sure all gain controls are set to minimum. Gain controls should be used only if absolutely necessary. Turning up gain controls causes increased noise, makes distortion more likely and reduces the dynamic range of your system. If you head unit does not have sufficient output, you will get much better results by investing in a line driver to provide more signal to the amplifier.

Z-150.2 SP / Z-400.2 SP Input Ends

The Input ends of the SP amplifiers is where you find the signal input connectors and the various controls. All the SP amps have the same basic functions, adapted slightly to fit the expected use of each model.

We look first at the stereo (2-Channel) amps. The 550 watt (Bridged @ 4Ω) Z-150.2 SP and the 1400 watt (bridged @ 4Ω) Z-400.2 SP, since they share exactly the same functions and controls.

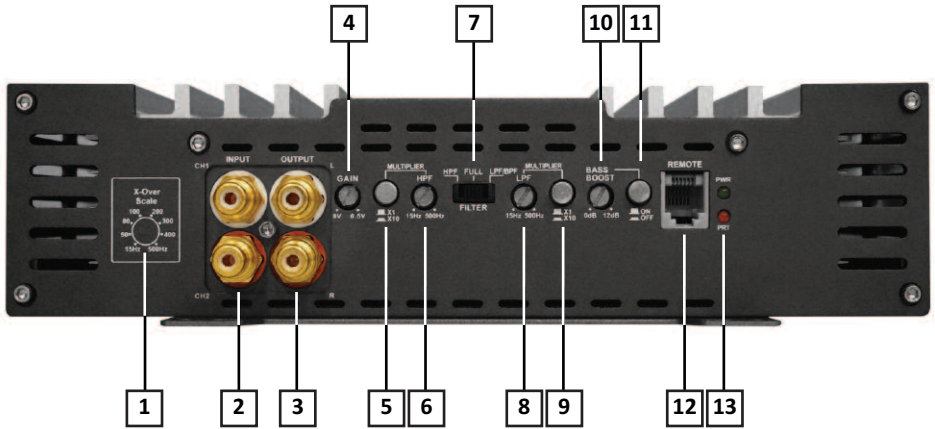

- 1• This is the scale for setting the crossover frequencies to assist in accurate settings
- 2• Right and left RCA input connectors using Zapco's proprietary gold plated connectors
- 3• To ease multi-amp installations, the amps have pass-through RCA outputs so you can "daisy-chain" multiple amps while only running one front-to-back RCA.
- 4• Variable gain control, see note Setting Gains.
- 5• A unique feature of the SP crossovers is the Multiplier x10 switch that allows accurate frequency setting by changing the crossover range from 15 Hz~500Hz to 150Hz~5000Hz. This is so you can use the amp full range, as a mid range (band-pass), or even as a tweeter amp.
- 6• The high-pass (HP) crossover frequency selector

- 7• The Crossover function switch: To the left the switch is in high-pass mode, in the center the crossover is out of the signal path (full-range), to the right both filters are in the circuit so you can band-pass. If you are using the amp for bass the LP will be your sub crossover while HP filter will be a variable sub-sonic filter as low as 15Hz
- 8• The low-pass (LP) frequency selector
- 9• The X10 switch for the LP filter
- 10• Variable bass boost control 0dB~12dB
- 11• Variable bass boost on/off
- 12• Port for the optional bass control
- 13• The power on (green) LED and the protect (red) LED

Note: If you are using an amp for a band-pass midrange, the HP filter will be the lowest frequency of the band and the LP filter will be the top of the band. This passes all the frequencies between them. If you reverse the filters you will have no sound.

Z-150.4 SP Input Ends

The Z-150.4 SP is the 4Ch amp and has the same basic controls and features as the 2Ch amps but adapted for 4-channel use.

- The front channels do not have a low pass filter as they will be used either full range or for mids/highs or even tweeters
- The rear channels have exactly the same controls as the 2-Channel amps as the rears will be used as full-range or bass, depending on the application, or even band-pass if the amp is used for tweeters (Ch1/2) and mid-range's (Ch3/4).
- The Z-150.4 SP adds a 2Ch/4Ch switch so you can choose to have only the Ch1/2 inputs feed both front and rear

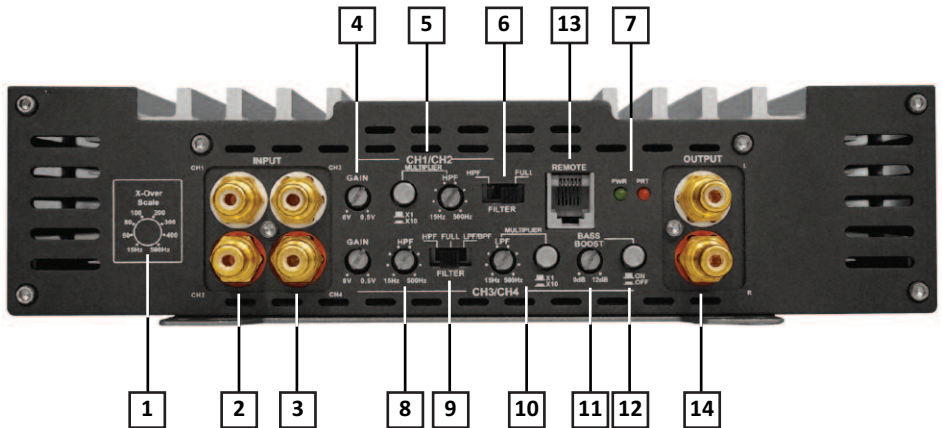

- | | |
|---|---|
| <p>1• Crossover frequency scale*</p> <p>2• Front (Ch1/2) RCA inputs</p> <p>3• Rear (Ch2/4) RCA inputs</p> <p>4• Front and rear variable gain controls</p> <p>5• Fnt. (Ch 1/2) Multiplier and HPF frequency control*</p> <p>6• Crossover mode select (HPF or Full)</p> <p>7• The power on (green) LED and the protect (red) LED</p> | <p>8• Rear (Ch3/4) HPF frequency control</p> <p>9• Rear crossover mode switch*</p> <p>10• Rear (Ch3/4) Multiplier and LPF frequency control*</p> <p>11• Variable bass boost control 0dB~12dB</p> <p>12• Variable bass boost on/off</p> <p>13• Port for the optional bass control</p> <p>14• Auxiliary pass-through RCA output*</p> |
|---|---|

* See explanations of these functions on the previous section 2-Channel amps #1,3,5,7

Z-150.6 SP Input Ends

The Z-150.6 SP is the 6-Channel SP amp and it also has the same basic controls and features as the other amps but has been adapted for 6-channel use.

- The channels 1/2 do not have a low-pass filter as they will be used either full range or for mids/highs so there is only high pass here
- Ch. 3/4 have high pass, full range, and low pass positions so they can be used for highs, or they can be band-passed for mid-range use
- Ch. 5/6 do not have a crossover function switch as they are band pass only They can be used as the bass section with the low-pass and a variable sub sonic. The sub sonic (which is high-pass), however has a wide frequency range so it can be used as the bottom of a band-pass to drive mid-bass drivers, if you have a separate sub amp
- The input mode switch lets you use 2Ch, 4Ch, or 6Ch of input, so you can drive all the channels from a single 2Ch stereo output from a head unit

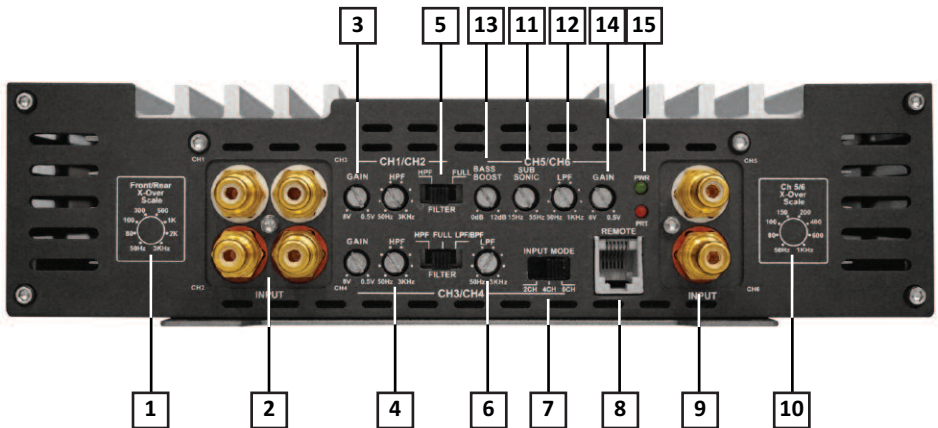

- 1• Frequency scale for front and rear crossovers (Ch 1/2 and 3/4)*
- 2• Ch1/2 and Ch3/4 RCA inputs
- 3• Ch1/2 and Ch3/4 variable gain controls
- 4• Ch1/2 and Ch3/4 HPF frequency controls
- 5• Ch1/2 and 3/4 crossover mode switches
- 6• Ch3/4 LPF frequency control
- 7• Input mode for 2Ch, 4Ch, or 6Ch inputs

- 8• Port for optional dash remote
- 9• Ch 5/6 RCA inputs
- 10• Frequency scale for Ch5/6 crossovers*
- 11• Ch5/6 Sub sonic (HP) frequency control
- 12• Ch5/6 LP bass crossover frequency control
- 13• Variable bass boost control
- 14• Ch5/6 variable gain control
- 15• The power on (green) LED and the protect (red) LED

* See explanations in Z-150.2P #1

Speaker Wiring of the SP Amplifiers

The Very Basics

- No speaker wires can be shorted to, or touching either ground or each other. This will put the amp into protect and may damage the amplifier
- When bridging the left and right channels of any SP amplifier, you use the left channel (Ch1) positive and the right channel (Ch2) negative, as indicated on the chassis by the speaker terminals

Z-150.2 SP / Z-400.2 SP Speaker Wiring

Stereo Mode

- Commonly a pair of full range speakers with x10 swt. off (out or x1 position) and HPF set between 70Hz~100Hz to protect the speakers from deep bass
- To use for tweeters put Multiplier switch to x10 (pushed in) and set HPF between 2000Hz~5000Hz, as per the tweeter makers recommendation
- To use for midrange: Determine the range of frequencies you want. Put the LPF/BPF Multiplier switch to x10 (pushed in) and set the LPF filter to the highest frequency you want to have. Set the HPF filter to the lowest frequency you want to have

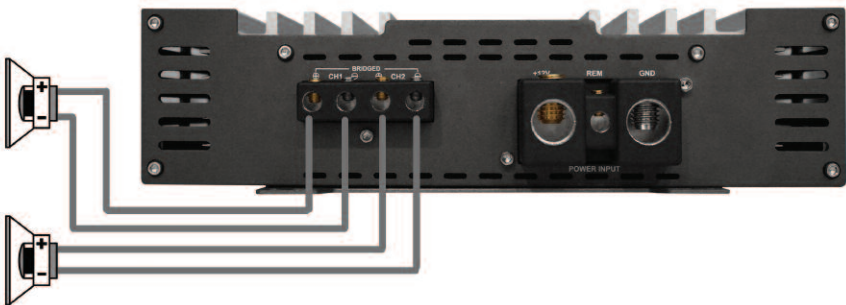

Single Channel Mode

Bridged to one voice coil using L+ and R-

- Commonly for a woofer. Set crossover mode to LPF/BPF with Multiplier to off (x1)
- Set LPF freq. to woofer maker's recommendation. Set HPF crossover freq. to 20Hz to use as a sub sonic filter

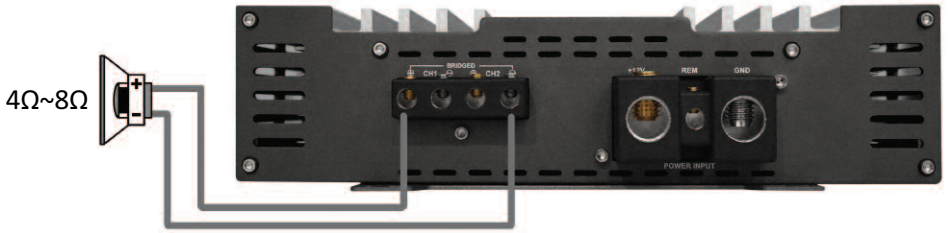

3Ch Mode

It is possible to run the 2Ch amps in “3-Channel” mode by running a pair of speakers for the mids and highs on left and right channels, and at the same time run a woofer bridged between the L+ and R- terminals as shown. However, since each channel will see 1/2 the impedance of the woofer you must use a woofer of no less than 4Ω. The amplifier sees impedance by frequency, so you can have two 2Ω loads but you must use a passive crossover on each speaker in the three channel mode. With the crossovers in the line, the amplifier will always see a minimum load of 2Ω on each channel at all frequencies.

- Main speakers can be 2Ω~4Ω. Woofer can be 4Ω~8Ω but cannot be less than 4Ω
- HP crossover can be FULL or can be HPF to be used between 15Hz and 25Hz as sub sonic filter
- LP crossover must be set to FULL
- All actual crossover functions will be done by the passive crossovers in the lines

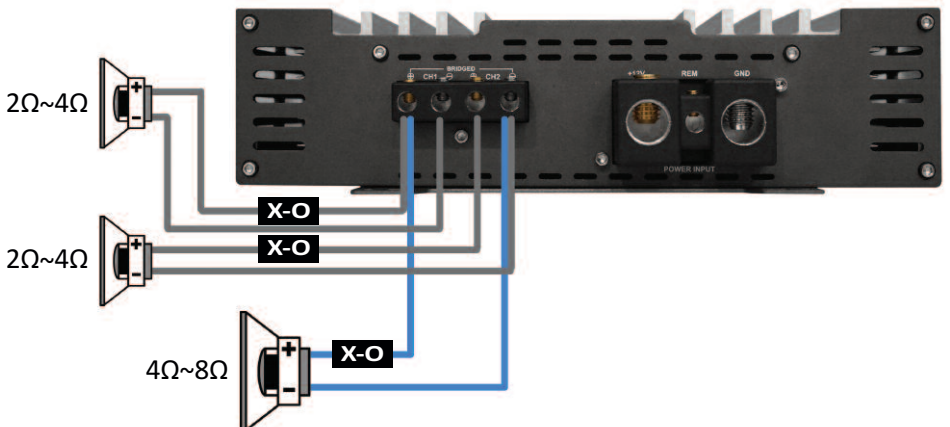

Z-150.4 SP Speaker Wiring

Standard 4Ch Mode

The Z-150.4 SP four channel amplifier is virtually two 2Ch amps in one chassis and each set of four speaker terminal can be used exactly as you would use a 2Ch amp. The advantage of a four channel amp is primarily the saving of space (and a little money). Using a four channel also reduces the installation work, over installing two 2Ch amps. This is especially so with some of the unique features of the Z-Series SP amps.

- This is the standard hookup for full range front and rear speakers
- Speakers can be $2\Omega\sim 4\Omega$
- If the head unit has 2 sets of RCA outputs you will be able to fade front to rear. If you have only one output, you can put the 2Ch/4Ch switch into the 2Ch position and use only the front (Ch1/2) inputs to feed all 4 channels
- You don't have to use crossovers, but it's wise to use the HPF filters set to 30Hz or a little more as a sub sonic filter to protect the speakers. Best policy is to check your speakers frequency range. Set the sub sonic (HP) frequency just a little above to lowest of the speakers frequency range. i.e If the speakers range is 40Hz~18,000Hz set filter to 45Hz. The LPF switches should be in FULL
- The HPF Multiplier (x10 switch) must be in the off or x1 position

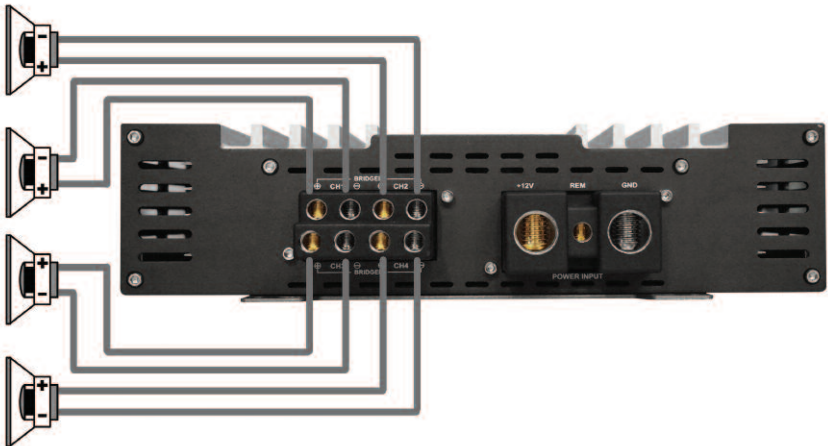

4Ch 2-Way Mode

With the unique features of the Z-Series amplifiers you can also use the Z-150.4 SP to drive a 2-way system with the front channels for highs and the rear channels for lows. The unique crossover will let you separate high and low like most 4Ch amps, but with the added range provided by the multiplier (x10) switch you can actually have a tweeter crossover as high as 5,000Hz on the front channels. With the SP series' band-pass functions, you can have the rears play everything below the tweeters, or you can have the rears play only midrange and use a separate amp for your subs.

For the diagram below of an active 2-way system:

- Front (1/2) crossover is set to HPF and multiplier switch set to x10 (in). HP frequency is set to the tweeter's recommended cut-off point (usually between 2KHz and 5KHz)
- You can set the Input Mode switch to 2Ch or 4Ch (if you want to fade highs to lows), but it is safest to use 2Ch mode
- Set the rear filter to LPF/BPF so both the rear filters are active
- Set the LPF/BPF multiplier switch to x10 (in) and set the frequency to the same frequency that was used on the tweeter high-pass filter
- If the lows speaker will be used as woofers then set the rear (3/4) HPF to around 30Hz as a sub sonic filter
- If another amp will be used for bass and channels 3/4 will be used a midrange, then set the rear HP filter to the frequency where the woofer will begin operating (usually 80Hz~120Hz)

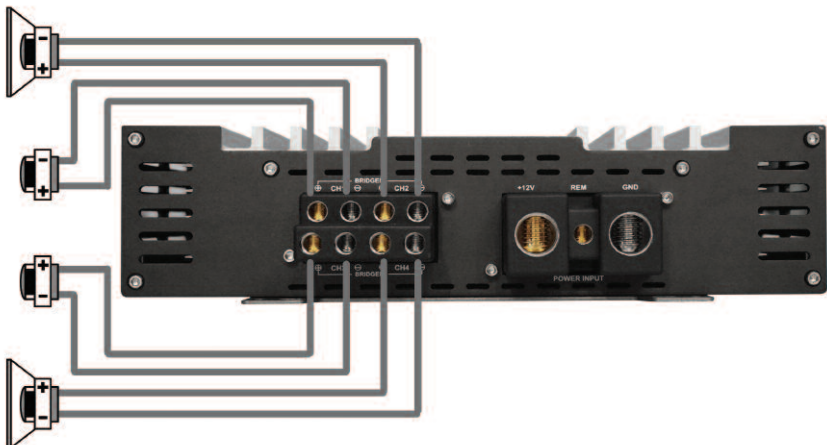

2-Way w/Bridged Mono Sub

A similar setup uses a pair of full-range speakers with a mono subwoofer.

- Front filter is set to HPF, the Multiplier is off (out), HP frequency is set just above the bottom of the full-range speaker's frequency range, where you will also set the woofer crossover
- If the head unit has a sub out set the Input Mode to 4Ch. If it does not then you can choose to have a fader in 4Ch mode, or set it to 2Ch mode and use only the front inputs. You can order the optional dash bass control for the woofer on the rear channel bridge
- Set the rear Filter to LPF/BPF to have both filters active and the multiplier to off (x1). Set the rear LPF frequency to the desired woofer crossover point (which should match the front high pass filter), and set the HPF frequency to 15Hz~30Hz as a sub sonic filter

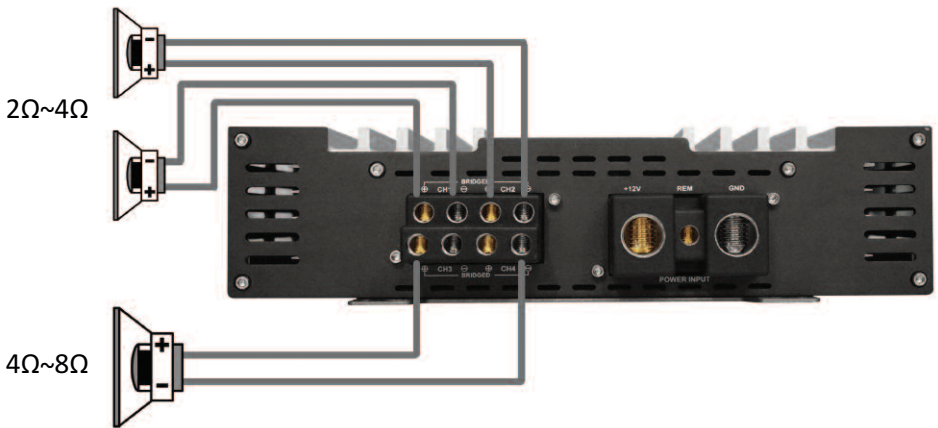

2Ch Bridged

Want more power? Instead of four channels of 165 watts, you can have two hannels of 550 watts each by bridging both front and rear amp sections to one speaker each.

- Speakers must be a minimum of 4Ω impedance
- Put the Input Mode switch into 4CH mode
- Using RCA "Y" adaptors of 1 female-to-2 male , put the left signal RCA into both L and R inputs of the front channels and put the right signal RCA into both L and R inputs of the rear channels.
- Do not use the optional dash bass control as it will only work on the speaker connected to the rear channels



Z-150.6 SP Speaker Wiring

Please read the special note about Channel 5 at pag. 1. The printing on the end plate is correct for + and - . While gold is normally the + terminal, some amps have left the factory with the colors reversed. However, the printing on the end plate is correct. Please note the correct - and + terminals in the speaker charts.

6Ch 6 speakers

The Z-150.6 is a 6-channel amp that can drive six speakers from 6, 4, or 2 channels of input. Note that channels 5 and 6 are arranged top and bottom and Ch5 has + and - reversed from the other channels.

That said:

- If you are driving full range speakers the only control you will really need is on Channels 1~4 are the HPF filter to use as a sub sonic. Channels 5 and 6 are designed for bass or mid-bass and plays from 15Hz to 1000Hz



A One-Amp, Active 3-way System

The Z-150.6 SP is a superbly versatile piece of gear. With the crossover features of this amp you can run a completely active 3-way system. You can run it as Tweeter , midrange, bass. You can also ruin it as tweeter, band-passed mid-range, and band passed mid-bass and then use a separate subwoofer amp. Below is an active 3-way system using a mono bass driver.

- The Input Mode switch can be set for 2,4,or 6 channels of input, but setting up a 3-way system is best done with a 2-channel input unless you are using a digital processor ahead of the amp
- Ch1/2 are used for tweeters. The multiplier is set to x10 (pushed in) with the Filter switch set to HPF. The HP frequency is set to tweeter's recommended HP range (usually between 2kHz~3kHz)
- Ch3/4 are mid-range. The Ch3/4 Filter switch is set to LPF/BPF so both filters are active. The HP frequency should be set to the frequency that the woofer will begin (usually between 80Hz~120Hz). The Ch3/4 LP frequency is set to the same frequency as the tweeter HP frequency (usually 2kHz~3kHz) that was set in the previous step
- Ch5/6 are bridged for a mono woofer. Ch5/6 always have both filters active. Set the LPF frequency to the same frequency as the Ch3/4 high pass filter, so the top of the woofer is the bottom of the midrange
- The bass boost should only be set after system is installed and you have had a chance to listen to see if any bass boost is needed

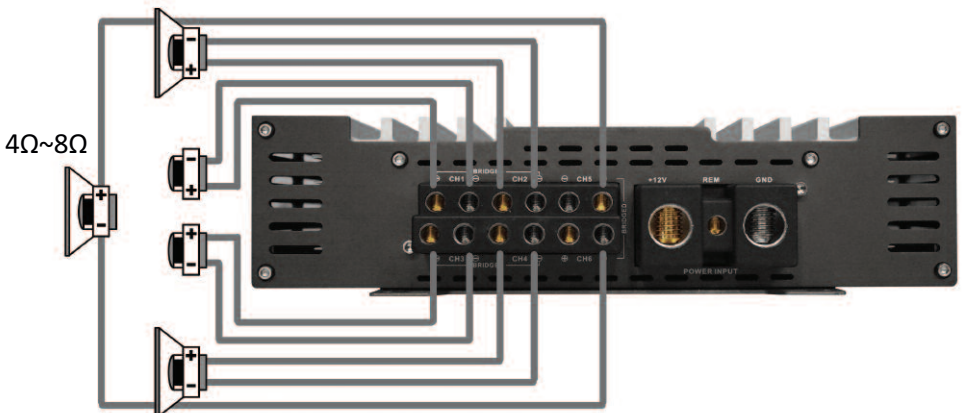

- Speakers on channels 1~4 must be minimum 2Ω of higher
- The bridged woofer must be 4Ω of higher
- You can add the optional dash control for the bass channels 5/6

High Power 2-way System

The system below provides plenty of power for a 2-way active system with even the lowest efficiency front speaker system. Each speaker has 550 watts RMS @ 4Ω

- Since all speakers are being bridged, they must all be minimum 4Ω~8Ω impedance
- Ch1/2 and 3/4 will use Filters set to HPF with frequency set to where the woofer will begin
- Ch5/6 will use the HP Sub Sonic filter at 15Hz~30Hz to protect the woofer. The low-pass filter should be set the HP frequency of the full-range speakers on Ch1/2 and Ch3/4

It is critical the crossover frequencies and gains of Ch1/2 and Ch3/4 are set exactly the same.

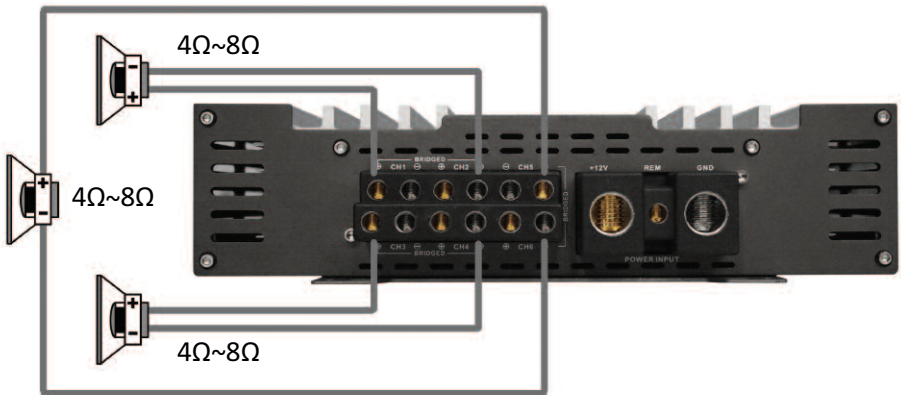

This same setup can also be used for a high power Left, Center, Right front stage.

Technical Specifications



Z-150.2 SP

Power @ 4Ω: 2 x 165 watts
Power @ 2Ω: 2 x 275 watts
Power @ 4Ω Bridged: 1 x 550 watts
THD @ Rated Power < 0.1%
Signal to Noise Ratio > 104dB
Channel separation > 60dB
Freq. Resp. 10Hz to 30,000Hz ±1dB
Input Sensitivity .25v to 8v
Dim. in mm: 241(W) x 62(H) x 301(L)
Overall: 241(W) x 62(H) x 328(L)
Recommended fuse: 70A fast blow



Z-400.2 SP

Power @ 4Ω: 2 x 440 watts
Power @ 2Ω: 2 x 700 watts
Power @ 4Ω Bridged: 1 x 1400 watts
THD @ Rated Power < 0.1%
Signal to Noise Ratio > 104dB
Channel separation > 60dB
Freq. Resp. 10Hz to 30,000Hz ±1dB
Input Sensitivity .25v to 8v
Dim. in mm: 241(W) x 62(H) x 482(L)
Overall: 241(W) x 62(H) x 514(L)
Recommended fuse: 180A fast blow



Z-150.4 SP

Power @ 4Ω: 4 x 165 watts
Power @ 2Ω: 4 x 275 watts
Power @ 4Ω Bridged: 2 x 550 watts
THD @ Rated Power < 0.1%
Signal to Noise Ratio > 104dB
Channel separation > 60dB
Freq. Resp. 10Hz to 30,000Hz ±1dB
Input Sensitivity .25v to 8v
Dim. in mm: 241(W) x 62(H) x 444(L)
Overall: 241(W) x 62(H) x 479(L)
Recommended fuse: 140A fast blow



Z-150.6 SP

Power @ 4Ω: 6 x 165 watts
Power @ 2Ω: 6 x 275 watts
Power @ 4Ω Bridged: 3 x 550 watts
THD @ Rated Power < 0.1%
Signal to Noise Ratio > 104dB
Channel separation > 60dB
Freq. Res. 10Hz to 30,000Hz ±1dB
Input Sensitivity .25v to 8v
Dim. in mm: 241(W) x 62(H) x 573(L)
Overall: 241(W) x 62(H) x 614(L)
Recommended fuse: 210A fast blow



Modesto, California USA
Since 1974

zapco.com